

CURRENT CLAMP FOR AC/DC CURRENT



PAC series

PAC clamps are professional current clamps designed to measure both AC and DC currents. The two jaw shapes available allow the user to clamp onto leads as well as small busbars.

Using the Hall effect principle, models in the PAC 10 series measure up to 400 A AC and 600 A DC, whilst those in the PAC 20 series reach 1,000 A AC and 1,400 A DC.

Powered by a battery or an optional standard external power supply via their micro USB connector, the PAC clamps all feature automatic DC zero adjustment and an automatic standby mode (Auto Power Off (APO)) that is disengageable.

The PAC 15 and PAC 25 models have a single measurement range with a sensitivity of 1 mV/A, allowing a so-called "direct" reading on the associated multimeter.

The PAC 16 and PAC 26 models feature a second, more sensitive 10 mV/A calibre.

The PAC 17 and PAC 27 models, also known as "isolated current probes", are dual-range and equipped with a coaxial lead and an isolated BNC connector so that they can be connected directly to an oscilloscope, allowing the current to be displayed in terms of both waveform and amplitude.

CURRENT CLAMPS FOR AC/DC CURRENT

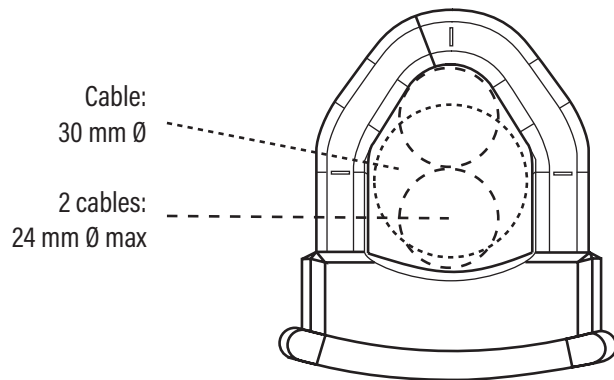

Cable:
30 mm Ø

2 cables:
24 mm Ø max

Jaws
PAC15, 16 and 17

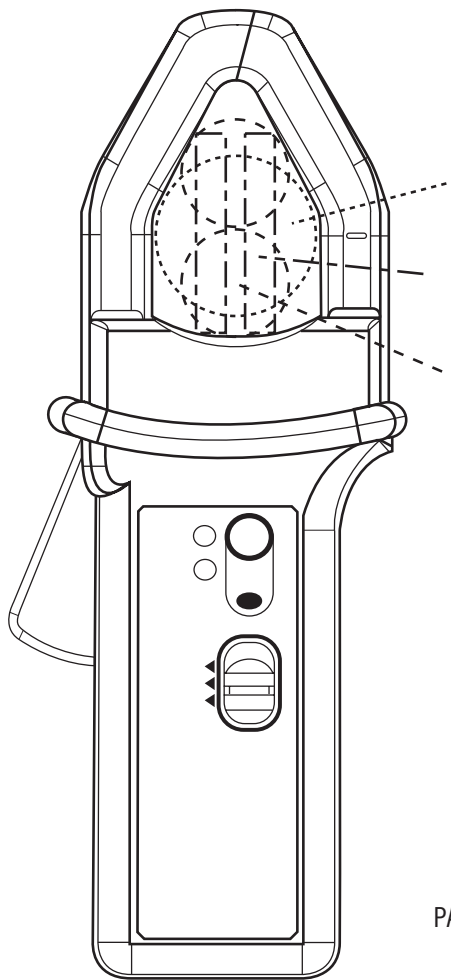

Cable:
39 mm max Ø

2 busbars:
50 x 5 mm max

2 cables:
25 mm max Ø

PAC 25, 26 and 27

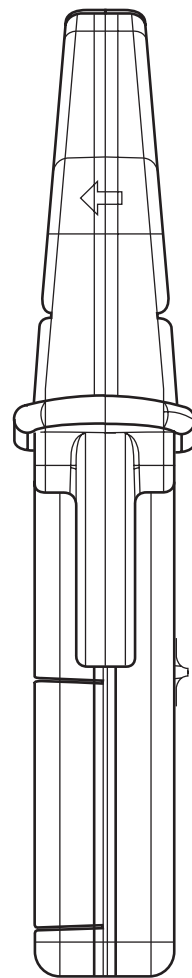

224 mm
(PAC 15, 16 and 17)

236,5 mm
(PAC 25, 26 and 27)

97 mm

44 mm

CURRENT CLAMP FOR AC/DC CURRENT

Model PAC15

Current	400 A AC 600 A DC
Output	1 mV/A

Description

The PAC15 model provides accurate measurement of AC or DC currents using the Hall effect principle. This mV-output clamp meter is equipped with an automatic DC zero system and a disengageable Auto Power Off (APO) function, and can be powered by a standard mains adapter via a Micro USB connector.

Electrical specifications

- Current range:**
0.5 A AC .. 400 A AC (600 A peak) / 0.5 A DC .. 600 A DC
- Output signal:**
1 mV AC+DC / A AC+DC (0.6 V for 600 A)
- Accuracy and phase shift ⁽¹⁾:**

Primary current:	0.5 A .. 3 A	3 A .. 100 A	100 A .. 300 A	300 A .. 400 A	400 A .. 500 A (DC only)	500 A .. 600 A (DC only)
Accuracy in % of output signal	≤ 2 % + 1.5 mV	≤ 2 % + 1.5 mV	≤ 2 %	≤ 2 %	≤ 3 %	≤ 4 %
Phase shift ⁽²⁾	Not specified	≤ 2.2 °	≤ 2.2 °	≤ 1.5 °	-	-

- Bandwidth:**
DC .. 30 kHz at -3 dB (depending on current value)
- Insertion impedance:**
0.01 mΩ at 400 Hz, 0.12 mΩ at 1 kHz
- Maximum currents:**
3,000 A DC or 1,000 A AC continuous for a frequency < 1 kHz (limitation proportional to the inverse of one third of frequency beyond)
- DC zero adjustment:**
Automatic, in increments of 40 to 60 mA
- AC output noise:**
≤ 1 mV peak-to-peak
- Power supply:**
9 V alkaline (NEDA 1604A, IEC 6LR61)
5 V DC Micro USB type B
- Battery life:**
50 hours typical
- Consumption:**
Typical 10 mA (battery)
Typical 31 mA (5 V μUSB)
- "ON" LED indicator:**
"On" = In operation & battery level OK
"Flashing" = Battery life < 4 hours
"Colour = green" = APO ON
"Colour = yellow" = APO OFF
- "OL" LED indicator:**
Overload indication; current measured is too high for the calibre being used
- Effect of the power supply voltage:**
Null
- Influence of temperature:**
≤ 3 % of the measurement + 100 mA DC/°C
- Influence of relative humidity:**
≤ 0.5% at 10% to 85% RH at ambient temperature
- Influence of an adjacent conductor carrying a 50 Hz AC current, situated 23 mm from the clamp:**
< 10 mA/A
- Influence of an external field 400 A/m @ 50 Hz:**
< 1.3 A
- Influence of conductor position Ø 20 mm in jaws:**
≤ 1 %
- Influence of frequency ⁽³⁾:**
of 10 Hz .. 400 Hz: ≤ 1 % of Vs
of 400 Hz .. 10 kHz: ≤ 3.5 % of Vs
of 10 kHz .. 30 kHz: see curve
- Common mode rejection:**
> 90 dB A/V @ 50 Hz
- Remanence:**
0 to 50 A DC: 1.2 A typical
0 to 100 A DC: 2.3 A typical
0 to 200 A DC: 3.4 A typical
0 to 400 A DC: 4.8 A typical
0 to 600 A DC: 5.5 A typical
0 to 800 A DC: 5.8 A typical
- Output:**
1.5 m double-insulated lead with safety male plugs (4 mm)
- Dimensions:**
224 x 97 x 44 mm
- Mass:**
440 g with battery
- Operating temperature:**
-10°C to +55°C
- Storage temperature:**
-40°C to +80°C
- Max. temperature of clamped conductor (measured):**
+90 °C (+110 °C at peak)
- Max. jaw temperature:**
+80 °C
- Relative humidity for operation:**
0 to 85 % RH with a linear decrease above 35 °C
- Operating altitude:**
0 to 2,000 m
- Casing protection rating:**
IP 40 (IEC 60529)
- Drop test:**
1 m (IEC 60068-2-32)
- Self-extinguishing capability:**
UL94 V1
- Colours:**
Dark grey case with red jaws

Mechanical specifications

- Max. jaw opening:**
31 mm
- Clamping capacity:**
Cables: Ø 30 mm
Ø 24 mm x 2
Busbars: 1 busbar 50 x 10 mm
2 busbars 31.5 x 10 mm
3 busbars 25 x 8 mm
4 busbars 25 x 5 mm



CURRENT CLAMPS FOR AC/DC CURRENT

Model PAC15

Safety specifications

- Electrical safety:**
 Type A instrument, with double insulation or reinforced insulation between the primary, the secondary and the grippable part located under the guard as per CEI 61010-1 & CEI 61010-2-032
 - 600 V category III, pollution degree 2
 - 300 V category IV, pollution degree 2
- Electromagnetic compatibility (EMC):**
 Compliant with IEC 61326-1 (portable instrument)

Curves

Linearity with DC

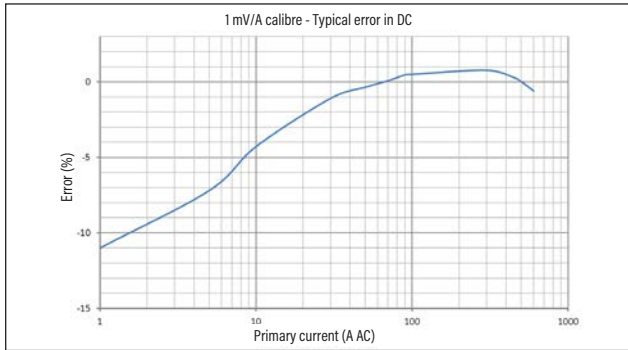

Linearity with AC

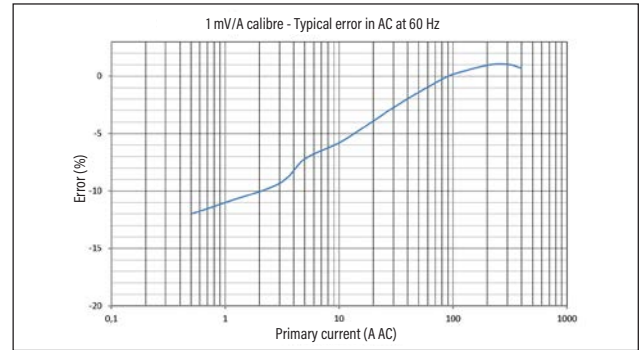

Phase shift

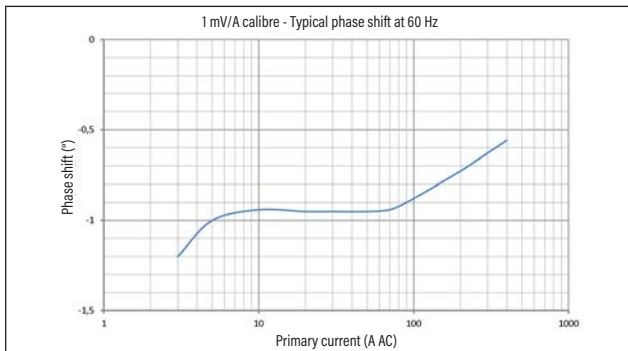

Limitation of measurable current according to frequency

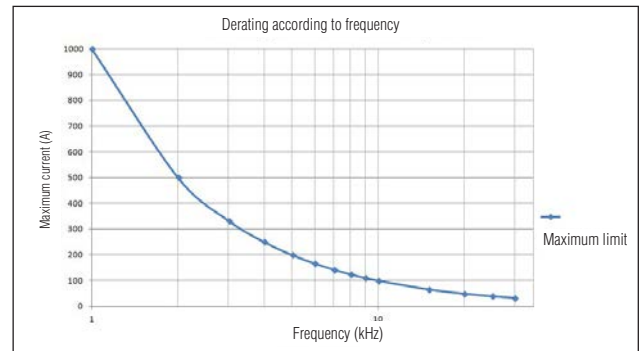

Frequency response

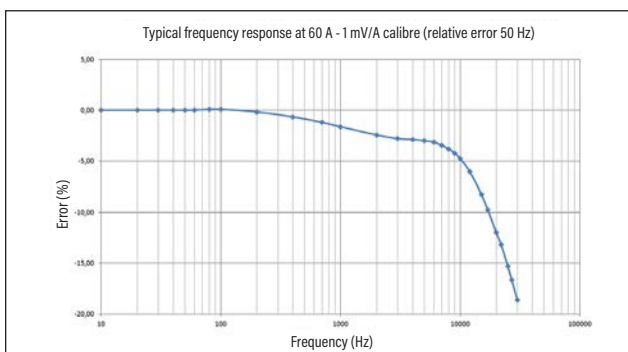

Frequency phase shift

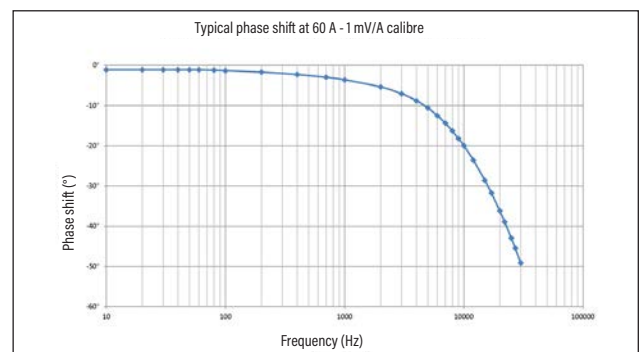

- (1) Conditions of reference:
 Temperature & humidity: 23 °C ± 5 °K, 20% to 75% RH
 Power supply: via a battery between 6 V and 9 V, via USB 5 ± 0.1 VDC
 Position of the conductor centred on the clamp markings
 Magnetic field: continuous Earth's magnetic field.
 No external alternating magnetic field.
 No electric field.
 Measurement for a sinusoidal DC current at 65 Hz.
 Instrument impedance: > 1 MΩ ≤ 100 pF.

(2) Phase shift in "absolute value" (unsigned)

(3) Out of reference domain

To order

AC/DC current clamps, model PAC15, with battery and user manual

Reference

P01120115

CURRENT CLAMP FOR AC/DC CURRENT

Model PAC16

Current	40 A AC 60 A DC	400 A AC 600 A DC
Output	10 mV/A	1 mV/A

Description

The PAC16 model provides accurate measurement of AC or DC currents using the Hall effect principle. This mV-output clamp meter is equipped with an automatic DC zero system and a disengageable Auto Power Off (APO) function, and can be powered by a standard mains adapter via a Micro USB connector.

Electrical specifications

- Current range:**
0.2 A AC .. 40 A AC (60 A peak) / 0.4 A DC .. 60 A DC
0.5 A AC .. 400 A AC (600 A peak) / 0.5 A DC .. 600 A DC
- Output signal:**
10 mV AC+ DC / A AC+ DC (0.6 V at 60 A)
1 mV AC+ DC / A AC+ DC (0.6 V at 600 A)
- Accuracy and phase shift ⁽¹⁾:**
- 60 A calibre

Primary current:	0.5 A .. 1 A	1 A .. 20 A	20 A .. 30 A	30 A .. 40 A	40 A .. 60 A (DC only)
Accuracy in % of output signal	≤ 3 % + 8 mV	≤ 3 % + 8 mV	≤ 3 % + 8 mV	≤ 1.5 %	≤ 1.5 %
Phase shift ⁽²⁾	Not specified	≤ 3°	≤ 2.2°	≤ 2.2°	-

- 600 A calibre

Primary current:	0.5 A .. 3 A	3 A .. 100 A	100 A .. 300 A	300 A .. 400 A	400 A .. 500 A (DC only)	500 A .. 600 A (DC only)
Accuracy in % of output signal	≤ 2 % + 1.5 mV	≤ 2 % + 1.5 mV	≤ 2 %	≤ 2 %	≤ 3 %	≤ 4 %
Phase shift ⁽³⁾	Not specified	≤ 2.2°	≤ 2.2°	≤ 1.5°	-	-

- Bandwidth:**
DC .. 30 kHz at -3 dB (depending on current value)
- Insertion impedance:**
0.01 mΩ at 400 Hz, 0.12 mΩ at 1 kHz
- Maximum currents:**
3,000 A DC or 1,000 A AC continuous for a frequency < 1 kHz (limitation proportional to the inverse of one third of frequency beyond)
- DC zero adjustment:**
Automatic, in increments of 40 to 60 mA
- AC output noise:**
- 60 A calibre: ≤ 3 mV or 0.3 A peak-peak
- 600 A calibre: ≤ 1 mV or 1 A peak-peak
- Power supply:**
9 V alkaline (NEDA 1604A, IEC 6LR61)
5 V DC Micro USB type B
- Battery life:**
50 hours typical
- Consumption:**
Typical 10 mA (battery)
Typical 31 mA (5 V μUSB)
- "ON" LED indicator:**
"On" = In operation & battery level OK
"Flashing" = Battery life < 4 hours
"Colour = green" = APO ON
"Colour = yellow" = APO OFF
- "OL" LED indicator:**
Overload indication; current measured is too high for the calibre being used
- Effect of the power supply voltage:**
Null
- Influence of temperature:**
≤ 3 % of the measurement + 100 mA DC/°C
- Influence of relative humidity:**
≤ 0.5% at 10% to 85% RH at ambient temperature
- Influence of an adjacent conductor carrying a 50 Hz AC current, situated 23 mm from the clamp:**
< 10 mA/A
- Influence of an external field 400 A/m @ 50 Hz:**
< 1.3 A
- Influence of conductor position**
Ø 20 mm in jaws:
≤ 1 %
- Influence of frequency ⁽⁴⁾:**
- Calibre 60 A: from 10 Hz .. 400 Hz: ≤ 1 % of Vs
of 400 Hz .. 7 kHz: ≤ 3.5 % of Vs
of 7 kHz .. 30 kHz: see curve
- Calibre 600 A: from 10 Hz .. 400 Hz: ≤ 1 % of Vs
of 400 Hz .. 10 kHz: ≤ 3.5 % of Vs
of 10 kHz .. 30 kHz: see curve
- Common mode rejection:**
> 90 dB A/V @ 50 Hz
- Remanence:**
0 to 50 A DC: 1.2 A typical
0 to 100 A DC: 2.3 A typical
0 to 200 A DC: 3.4 A typical
0 to 400 A DC: 4.8 A typical
0 to 600 A DC: 5.5 A typical
0 to 800 A DC: 5.8 A typical



Mechanical specifications

- Max. jaw opening:**
31 mm
- Clamping capacity:**
Cables: Ø 30 mm
Ø 24 mm x 2
Busbars: 1 busbar 50 x 10 mm
2 busbars 31.5 x 10 mm
3 busbars 25 x 8 mm
4 busbars 25 x 5 mm
- Output:**
1.5 m double-insulated lead with safety male plugs (4 mm)
- Dimensions:**
224 x 97 x 44 mm
- Mass:**
440 g with battery
- Operating temperature:**
-10°C to +55°C
- Storage temperature:**
-40°C to +80°C

CURRENT CLAMPS FOR AC/DC CURRENT

Model PAC16

- **Max. temperature of clamped conductor (measured):**
+90 °C (+110 °C at peak)
- **Max. jaw temperature:**
+80 °C
- **Relative humidity for operation:**
0 to 85 % RH with a linear decrease above 35 °C
- **Operating altitude:**
0 to 2,000 m
- **Casing protection rating:**
IP 40 (IEC 60529)
- **Drop test:**
1 m (IEC 60068-2-32)
- **Self-extinguishing capability:**
UL94 V1
- **Colours:**
Dark grey case with red jaws

Safety specifications

- **Electrical safety:**
Type A instrument, with double insulation or reinforced insulation between the primary, the secondary and the grippable part located under the guard as per CEI 61010-1 & CEI 61010-2-032
 - 600 V category III, pollution degree 2
 - 300 V category IV, pollution degree 2
- **Electromagnetic compatibility (EMC):** :
Compliant with IEC 61326-1 (portable instrument)

Curves

60 A calibre

600 A calibre

Linearity with DC

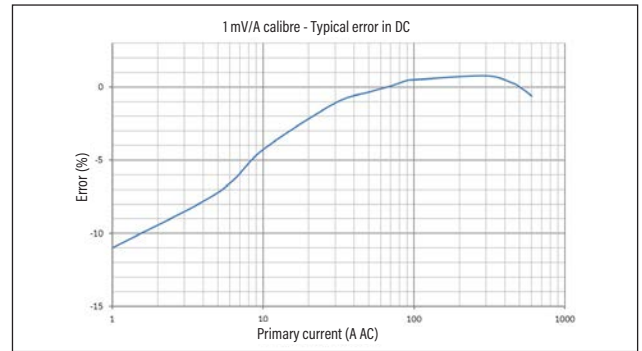
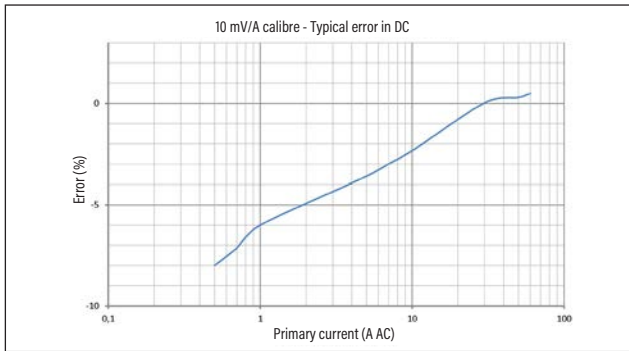

Linearity with AC

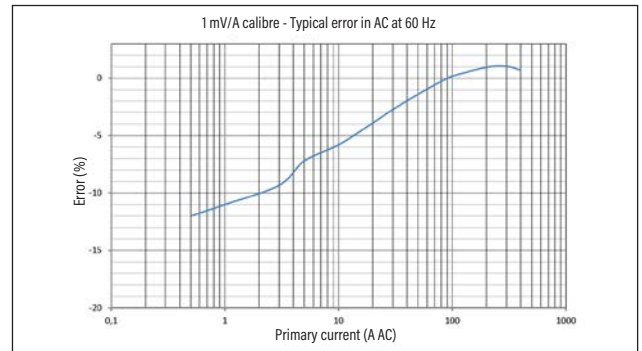
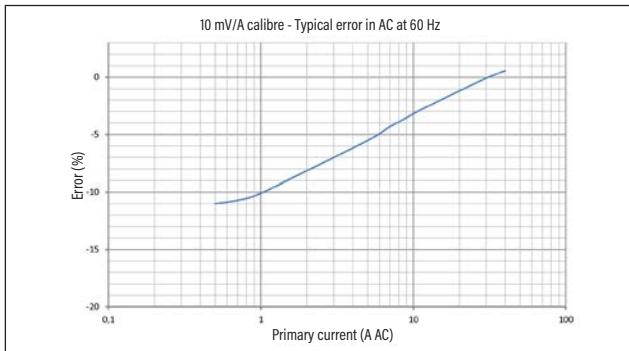

Phase shift

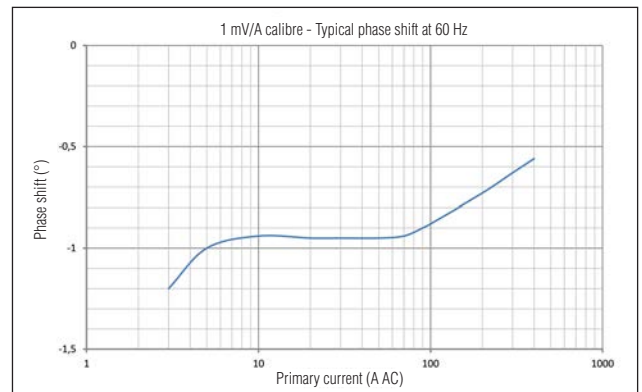
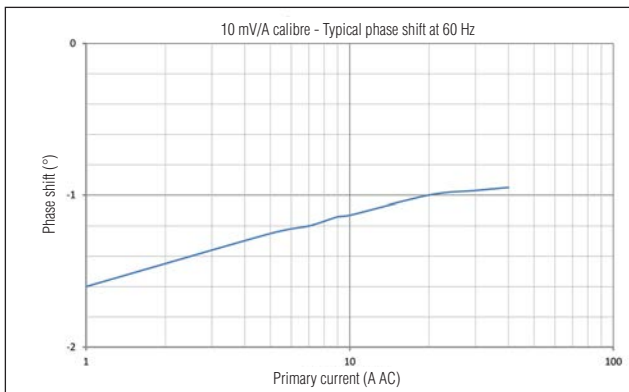

CURRENT CLAMP FOR AC/DC CURRENT

Model PAC16

Curves

Limitation of the measurable current as a function of frequency

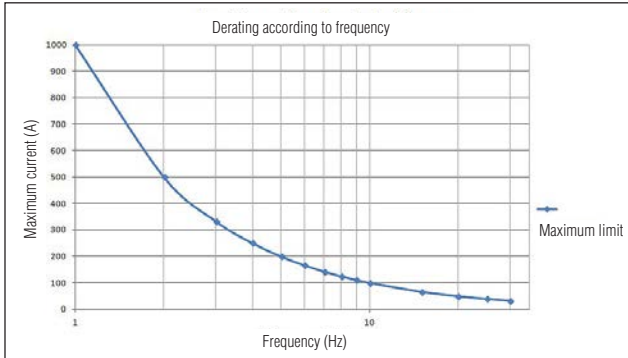

60 A calibre

600 A calibre

Frequency response

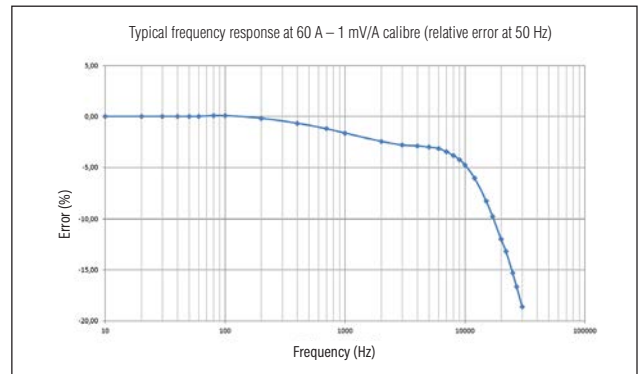
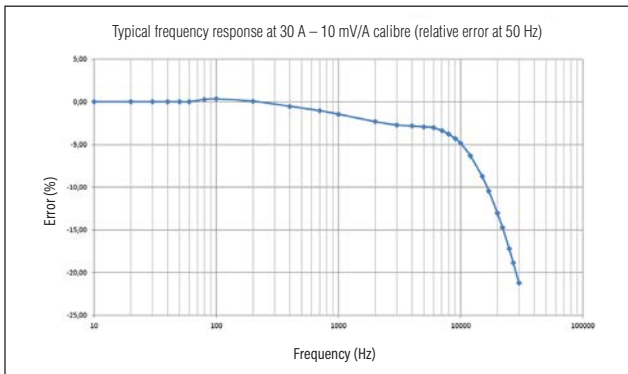

Frequency phase shift

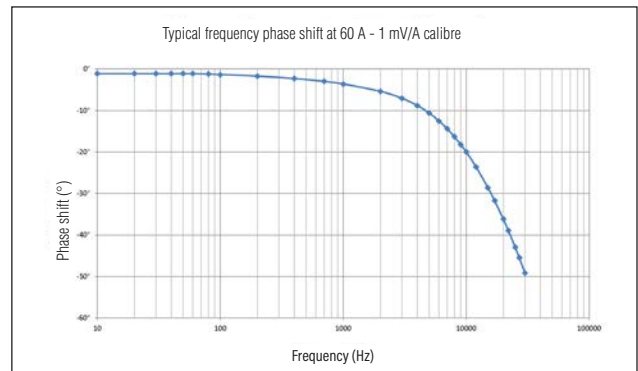
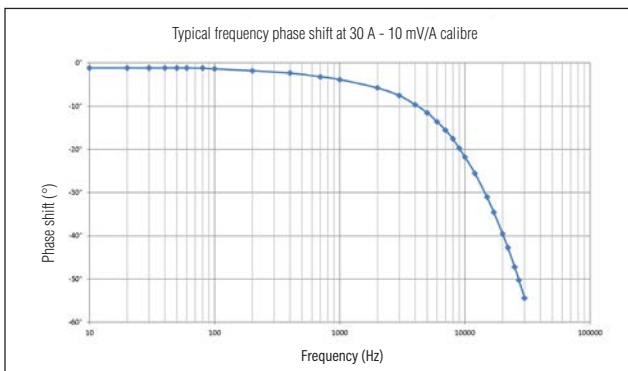

- (1) Conditions of reference:
 Temperature & humidity: 23 °C ± 5 °K, 20% to 75% RH
 Power supply: via a battery between 6 V and 9 V, via µUSB 5 ± 0.1 VDC
 Position of the conductor centred on the clamp markings
 Magnetic field: continuous Earth's magnetic field.
 No external alternating magnetic field.
 No electric field.
 Measurement for a sinusoidal DC current at 65 Hz.
 Instrument impedance: > 1 MΩ ≤ 100 pF.
- (2) Phase shift in "absolute value" (unsigned)
- (3) Out of reference domain

To order	Reference
AC/DC current clamps, model PAC16, with battery and user manual	P01120116

CURRENT CLAMPS FOR AC/DC CURRENT

Model PAC17 (insulated AC/DC current probe)

Current	40 A AC 60 A DC	400 A AC 600 A DC
Output	10 mV/A	1 mV/A

Description

The PAC17 model provides accurate measurement of AC or DC currents using the Hall effect principle. This mV-to-BNC output clamp (for direct reading on oscilloscopes, etc.) is equipped with an automatic DC zero system and a disengageable Auto Power Off (APO) function, and can be powered by a standard mains adapter via a Micro USB connector.

Electrical specifications

- Current range:**
0.2 A AC .. 40 A AC (60 A peak) / 0.4 A DC .. 60 A DC
0.5 A AC .. 400 A AC (600 A peak) / 0.5 A DC .. 600 A DC
- Output signal:**
10 mV AC+ DC / A AC+ DC (0.6 V at 60 A)
1 mV AC+ DC / A AC+ DC (0.6 V at 600 A)
- Accuracy and phase shift ⁽¹⁾:**
60 A calibre

Primary current:	0.5 A .. 1 A	1 A .. 20 A	20 A .. 30 A	30 A .. 40 A	40 A .. 60 A (DC only)
Accuracy in % of output signal	≤ 3 % + 8 mV	≤ 3 % + 8 mV	≤ 3 % + 8 mV	≤ 1.5 %	≤ 1.5 %
Phase shift ⁽²⁾	Not specified	≤ 3°	≤ 2.2°	≤ 2.2°	-

- 600 A calibre

Primary current:	0.5 A .. 3 A	3 A .. 100 A	100 A .. 300 A	300 A .. 400 A	400 A .. 500 A (DC only)	500 A .. 600 A (DC only)
Accuracy in % of output signal	≤ 2 % + 1.5 mV	≤ 2 % + 1.5 mV	≤ 2 %	≤ 2 %	≤ 3 %	≤ 4 %
Phase shift ⁽³⁾	Not specified	≤ 2.2°	≤ 2.2°	≤ 1.5°	-	-

- Bandwidth:**
DC .. 30 kHz at -3 dB (depending on current value)
- Rise time (10% to 90% of Vs):**
≤ 11 μs
- Fall time (from 90% to 10% of Vs):**
≤ 11 μs
- 10 % delay time:**
≤ 10 μs
- Insertion impedance:**
0.01 mΩ at 400 Hz, 2.8 mΩ at 10 kHz
- Maximum currents:**
3,000 A DC or 1,000 A AC continuous for a frequency < 1 kHz (limitation proportional to the inverse of one third of frequency beyond)
- DC zero adjustment:**
Calibre 60 A & 600 A:
Automatic, in increments of 40 to 60 mA
- AC output noise:**
60 A calibre: ≤ 3 mV or 0.3 A peak-peak
600 A calibre: ≤ 1 mV or 1 A peak-peak
- Power supply:**
9 V alkaline (NEDA 1604A, IEC 6LR61)
5 V DC Micro USB type B
- Battery life:**
50 hours typical
- Consumption:**
Typical 10 mA (battery)
Typical 31 mA (5 V μUSB)
- "ON" LED indicator:**
"On" = In operation & battery level OK
"Flashing" = Battery life < 4 hours

"Colour = green" = APO ON
"Colour = yellow" = APO OFF

- "OL" LED indicator:**
Overload indication; current measured is too high for the calibre being used
- Effect of the power supply voltage:**
Null
- Influence of temperature:**
≤ 3 % of the measurement + 100 mA DC/°C
- Influence of relative humidity:**
≤ 0.5% at 10% to 85% RH at ambient temperature
- Influence of an adjacent conductor carrying a 50 Hz AC current, situated 23 mm from the clamp:**
< 10 mA/A
- Influence of an external field 400 A/m @ 50 Hz:**
< 1.3 A
- Influence of conductor position Ø 20 mm in jaws:**
≤ 1 %
- Influence of frequency ⁽²⁾:**
Calibre 60 A: from 10 Hz .. 400 Hz: ≤ 1 % of Vs
of 400 Hz .. 7 kHz: ≤ 3.5 % of Vs
of 7 kHz .. 30 kHz: see curve
Calibre 600 A: from 10 Hz .. 400 Hz: ≤ 1 % of Vs
of 400 Hz .. 10 kHz: ≤ 3.5 % of Vs
of 10 kHz .. 30 kHz: see curve
- Common mode rejection:**
> 90 dB A/V @ 50 Hz

- Remanence:**
0 to 50 A DC: 1.2 A typical
0 to 100 A DC: 2.3 A typical
0 to 200 A DC: 3.4 A typical
0 to 400 A DC: 4.8 A typical
0 to 600 A DC: 5.5 A typical
0 to 800 A DC: 5.8 A typical

Mechanical specifications

- Max. jaw opening:**
31 mm
- Clamping capacity:**
Cables: Ø 30 mm
Ø 24 mm x 2
Busbars: 1 busbar 50 x 10 mm
2 busbars 31.5 x 10 mm
3 busbars 25 x 8 mm
4 busbars 25 x 5 mm
- Output:**
Coaxial cable 2 m long, terminated by an insulated BNC connector
- Dimensions:**
224 x 97 x 44 mm
- Mass:**
440 g with battery
- Operating temperature:**
-10°C to +55°C



CURRENT CLAMP FOR AC/DC CURRENT

Model PAC17 (insulated AC/DC current probe)

- **Storage temperature:**
-40°C to +80°C
- **Max. temperature of clamped conductor (measured):**
+90 °C (+110 °C at peak)
- **Max. jaw temperature:**
+80 °C
- **Relative humidity for operation:**
0 to 85 % RH with a linear decrease above 35 °C
- **Operating altitude:**
0 to 2,000 m
- **Casing protection rating:**
IP 40 (IEC 60529)
- **Drop test:**
1 m (IEC 60068-2-32)
- **Self-extinguishing capability:**
UL94 V1
- **Colours:**
Dark grey case with red jaws

Safety specifications

- **Electrical safety:**
Type A instrument, with double insulation or reinforced insulation between the primary, the secondary and the grippable part located under the guard as per CEI 61010-1 & CEI 61010-2-032
 - 600 V category III, pollution degree 2
 - 300 V category IV, pollution degree 2
- **Electromagnetic compatibility (EMC):** :
Compliant with IEC 61326-1 (portable instrument)

Curves

60 A calibre

Linearity with DC

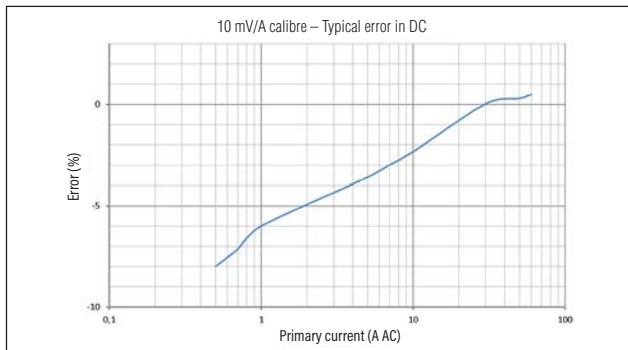

600 A calibre

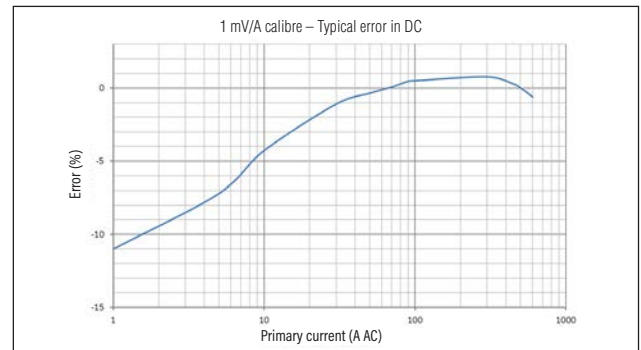

Linearity with AC

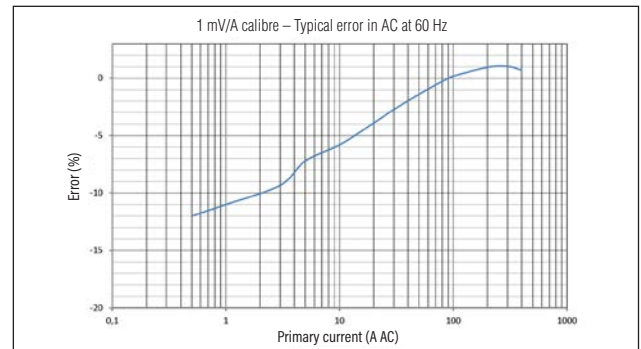
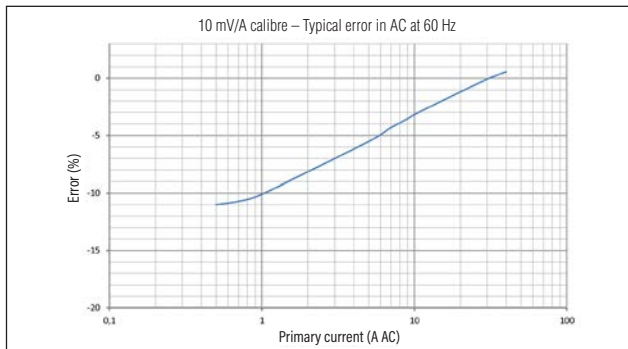

Phase shift

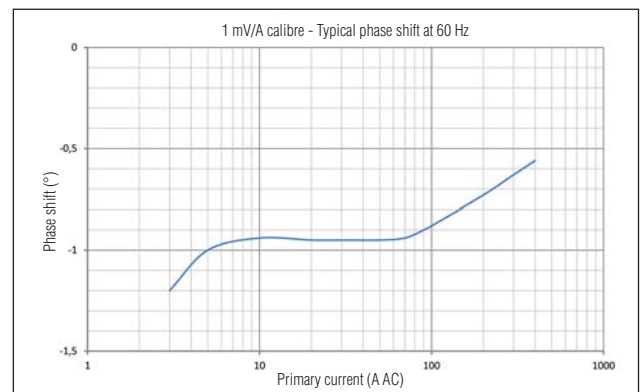
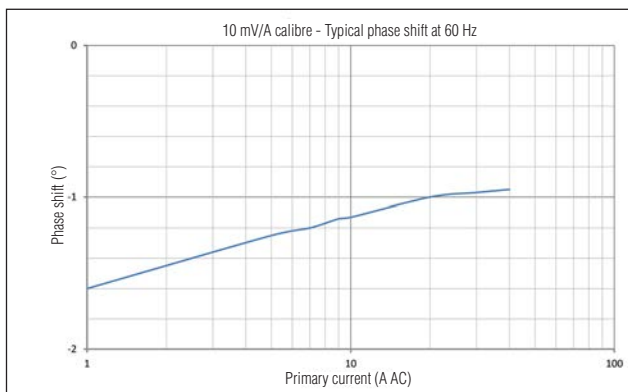

CURRENT CLAMPS FOR AC/DC CURRENT

Model PAC17 (insulated AC/DC current probe)

Curves

Limitation of the measurable current as a function of frequency

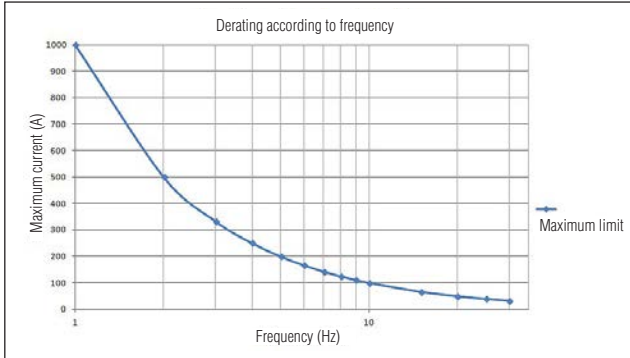

60 A calibre

600 A calibre

Frequency response

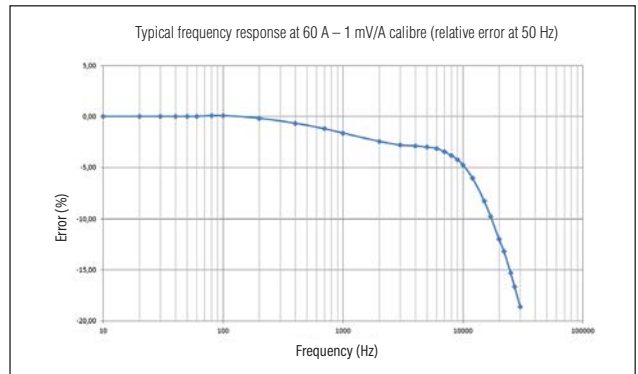
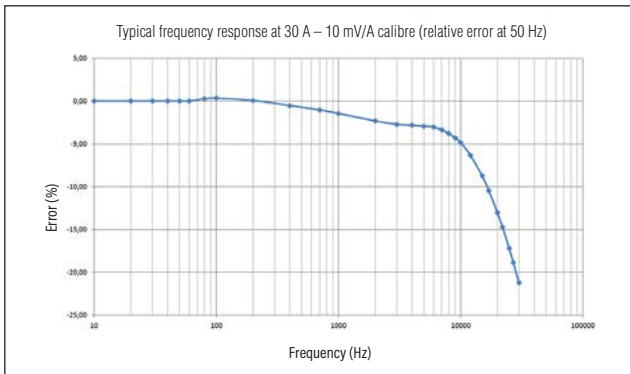

Frequency phase shift

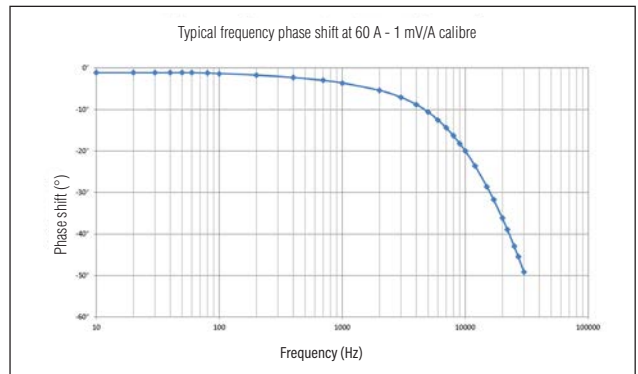
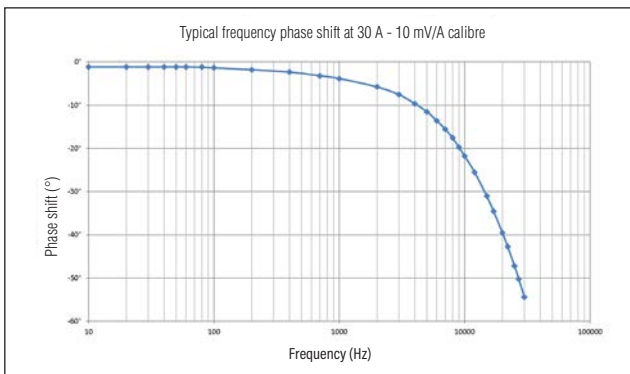

CURRENT CLAMP FOR AC/DC CURRENT

Model PAC17 (insulated AC/DC current probe)

Curves

60 A calibre

600 A calibre

Pulse response

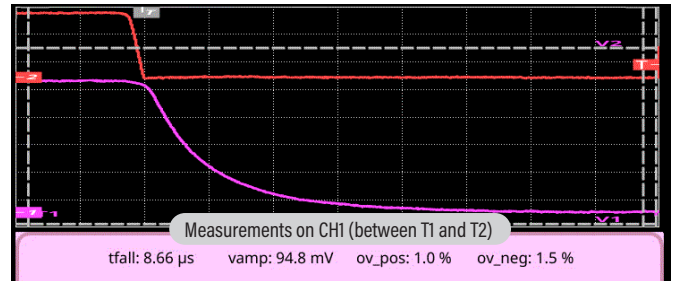
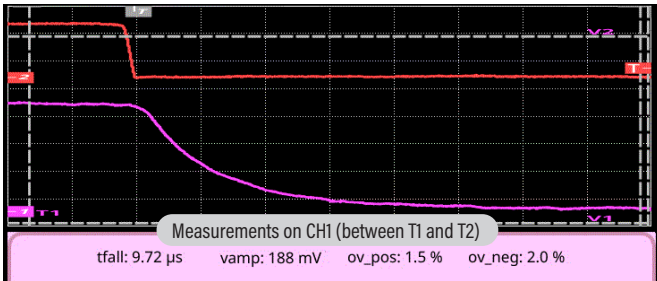
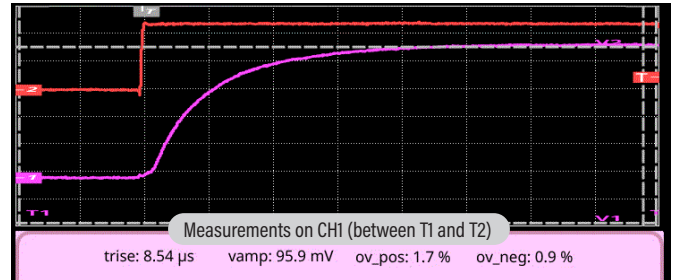
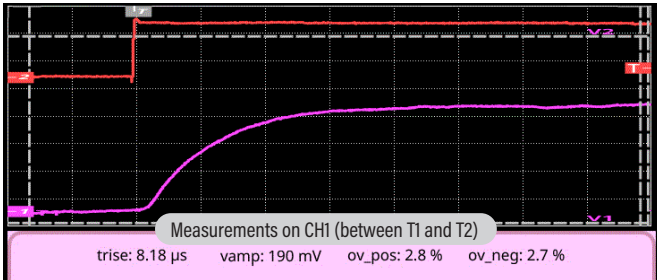

- (1) Conditions of reference:
 Temperature & humidity: 23 °C \pm 5 °K, 20% to 75% RH
 Power supply: via a battery between 6 V and 9 V, via μ USB 5 \pm 0.1 VDC
 Position of the conductor centred on the clamp markings
 Magnetic field: continuous Earth's magnetic field.
 No external alternating magnetic field.
 No electric field.
 Measurement for a sinusoidal DC current at 65 Hz.
 Instrument impedance: > 1 M Ω \leq 100 pF.
- (2) Out of reference domain

To order	Reference
AC/DC current clamp, model PAC17 , for oscilloscopes, with battery and operating user manual	P01120117

CURRENT CLAMPS FOR AC/DC CURRENT

Model PAC25

Current	1,000 A AC 1,400 A DC
Output	1 mV/A

Description

The PAC25 model provides accurate measurement of AC or DC currents using the Hall effect principle. This mV-output clamp meter is equipped with an automatic DC zero system and a disengageable Auto Power Off (APO) function, and can be powered by a standard mains adapter via a Micro USB connector.

Electrical specifications

- Current range**
0.5 A AC .. 1,000 A AC (1,400 A peak) / 0.5 A DC .. 1,400 A DC
- Output signal:**
1 mV AC+DC / A AC+DC (1.4 V for 1,400 A)
- Accuracy and phase shift ⁽¹⁾:**

Primary current:	0.5 A .. 3 A	3 A .. 100 A	100 A .. 200 A	200 A .. 800 A	800 A .. 1,000 A	1,000 A .. 1,400 A (DC only)
Accuracy in % of output signal	≤ 2% + 1.5 mV	≤ 2% + 1.5 mV	≤ 2.5%	≤ 2.5%	≤ 4%	≤ 5%
Phase shift ⁽²⁾	Not specified	≤ 2°	≤ 2°	≤ 1.5°	≤ 1.5°	-

- Bandwidth:**
DC .. 30 kHz at -3 dB (depending on current value)
- Insertion impedance:**
0.05 m at 400 Hz, 0.14 m at 1 kHz
- Maximum currents:**
3,000 A DC or 1,000 A AC continuous for a frequency < 1 kHz (limitation proportional to the inverse of one third of frequency beyond)
- DC zero adjustment:**
Automatic, in increments of 40 to 60 mA
- AC output noise:**
1 mV peak-peak
- Power supply:**
9 V alkaline (NEDA 1604A, IEC 6LR61)
5 V DC Micro USB type B
- Battery life:**
50 hours typical
- Consumption:**
Typical 10 mA (battery)
Typical 31 mA (5 V μ USB)
- "ON" LED indicator:**
"On" = In operation & battery level OK
"Flashing" = Battery life < 4 hours
"Colour = green" = APO ON
"Colour = yellow" = APO OFF
- "OL" LED indicator:**
Overload indication; current measured is too high for the calibre being used
- Effect of the power supply voltage:**
Null
- Influence of temperature:**
≤ 3 % of the measurement + 100 mA DC/°C
- Influence of relative humidity:**
0.5% at 10% to 85% RH at ambient temperature
- Influence of an adjacent conductor carrying a 50 Hz AC current, situated 23 mm from the clamp:**
< 10 mA/A

- Influence of an external field 400 A/m @ 50 Hz:**
< 1.3 A
- Influence of conductor position \varnothing 20 mm in jaws:**
0.5 %
- Influence of frequency ⁽²⁾:**
of 10 Hz .. 400 Hz: 1% of VS
of 400 Hz .. 10 kHz: 3.5 % of VS
of 10 kHz .. 30 kHz: see curve
- Common mode rejection:**
> 90 dB A/V @ 50 Hz
- Remanence:**
0 to 100 A DC: 2.8 A typical
0 to 200 A DC: 3.5 A typical
0 to 400 A DC: 5 A typical
0 to 800 A DC: 5.3 A typical
0 to 1,200 A DC: 5.7 A typical
0 to 1,400 A DC: 5.8 A typical

Mechanical specifications

- Max. jaw opening:**
39 mm
- Clamping capacity:**
Cables: \varnothing 39 mm
 \varnothing 25.4 mm x 2
Busbars: 1 busbar 50 x 12.5 mm
2 busbars 50 x 5 mm or 31.5 x 10 mm
3 busbars 25 x 8 mm
4 busbars 25 x 5 mm
- Output:**
1.5 m double-insulated lead with safety male plugs (4 mm)
- Dimensions:**
236.5 x 97 x 44 mm
- Mass:**
520 g with battery
- Operating temperature:**
-10°C to +55°C
- Storage temperature:**
-40°C to +80°C



- Max. temperature of clamped conductor (measured):**
+90 °C (+110 °C at peak)
- Max. jaw temperature:**
+80 °C
- Relative humidity for operation:**
0 to 85 % RH with a linear decrease above 35 °C
- Operating altitude:**
0 to 2,000 m
- Casing protection rating:**
IP 40 (IEC 60529)
- Drop test:**
1 m (IEC 60068-2-32)
- Self-extinguishing capability:**
UL94 V1
- Colours:**
Dark grey case with red jaws

Safety specifications

- Electrical safety:**
Type A instrument, with double insulation or reinforced insulation between the primary, the secondary and the grippable part located under the guard as per CEI 61010-1 & CEI 61010-2-032
- 600 V category III, pollution degree 2
- 300 V category IV, pollution degree 2
- Electromagnetic compatibility (EMC):** :
Compliant with IEC 61326-1 (portable instrument)

CURRENT CLAMP FOR AC/DC CURRENT

Model PAC25

Curves

Linearity for DC

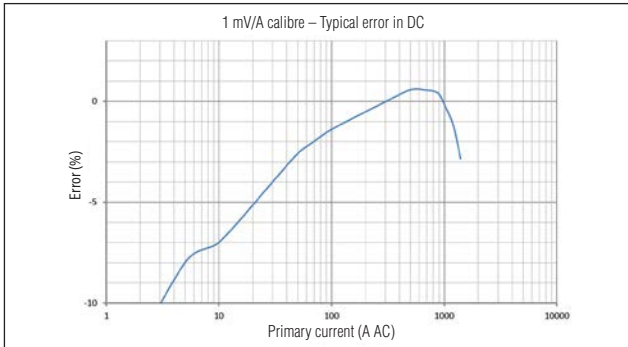

Linearity for AC



Phase shift

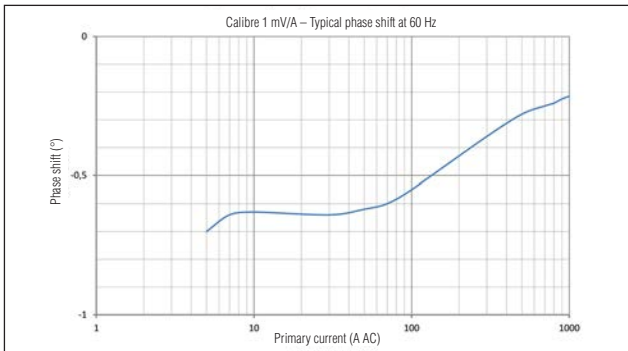

Limitation of the measurable current as a function of frequency

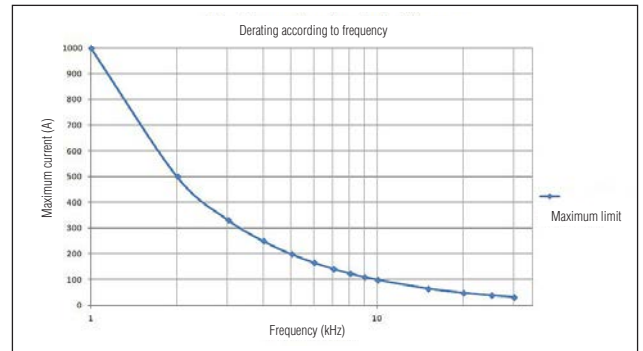

Frequency response

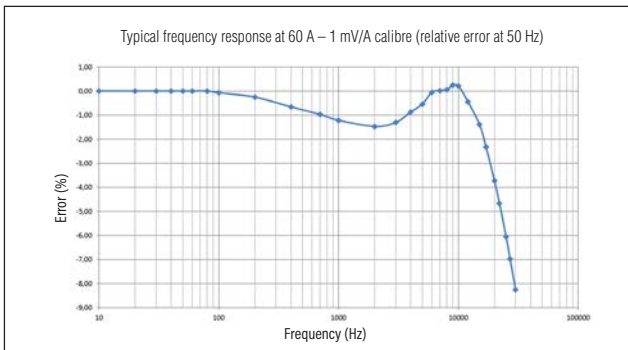

Frequency phase shift

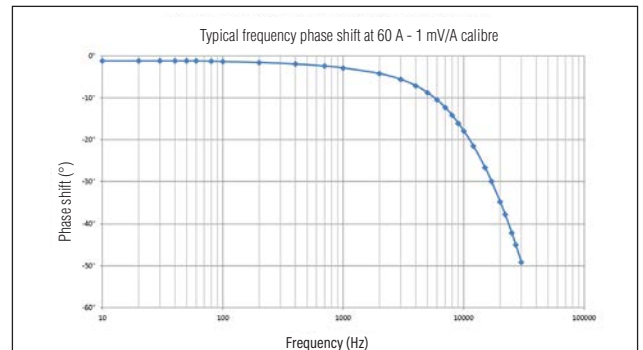

- (1) Conditions of reference:
 Temperature & humidity: 23 °C ± 5 °K, 20% to 75% RH
 Power supply: via a battery between 6 V and 9 V, via µUSB 5 ± 0.1 VDC
 Position of the conductor centred on the clamp markings
 Magnetic field: continuous Earth's magnetic field.
 No external alternating magnetic field.
 No electric field.
 Measurement for a sinusoidal DC current at 65 Hz.
 Instrument impedance: > 1 MΩ ≤ 100 pF.

- (2) Out of reference domain

To order	Reference
AC/DC current clamps, model PAC25, with battery and user manual	P01120125

CURRENT CLAMPS FOR AC/DC CURRENT

Model PAC26

Current	100 A AC 150 A DC	1,000 A AC 1,400 A DC
Output	10 mV/A	1 mV/A

Description

The PAC26 model provides accurate measurement of AC or DC currents using the Hall effect principle. This mV-output clamp meter is equipped with an automatic DC zero system and a disengageable Auto Power Off (APO) function, and can be powered by a standard mains adapter via a Micro USB connector.

Electrical specifications

- Current range:**
0.2 A AC .. 100 A AC (150 A peak) / 0.4 A DC .. 150 A DC
0.5 A AC .. 1,000 A AC (1,400 A peak) / 0.5 A DC .. 1,400 A DC
- Output signal:**
10 mV AC+ DC / A AC+ DC (0.6 V at 150 A)
1 mV AC+ DC / A AC+ DC (0.6 V at 1,400 A)
- Accuracy and phase shift ⁽¹⁾:**

150 A calibre

Primary current:	0.5 A .. 1 A	1 A .. 40 A	40 A .. 100 A	100 A .. 150 A (DC only)
Accuracy in % of output signal	≤ 3 % + 8 mV	≤ 3 % + 8 mV	≤ 1.5 %	≤ 1.5 %
Phase shift ⁽²⁾	Not specified	≤ 2°	≤ 2°	-

- 1,400 A calibre

Primary current:	0.5 A .. 3 A	3 A .. 100 A	100 A .. 200 A	200 A .. 800 A	800 A .. 1,000 A	1,000 A .. 1,400 A (DC only)
Accuracy in % of output signal	≤ 2 % + 1.5 mV	≤ 2 % + 1.5 mV	≤ 2.5 %	≤ 2.5 %	≤ 4 %	≤ 5 %
Phase shift ⁽³⁾	Not specified	≤ 2°	≤ 2°	≤ 1.5°	≤ 1.5°	-

- Bandwidth:**
DC .. 30 kHz at -3 dB (depending on current value)
- Insertion impedance:**
0.05 mΩ at 400 Hz, 0.14 mΩ at 1 kHz
- Maximum currents:**
3,000 A DC or 1,000 A AC continuous for a frequency < 1 kHz (limitation proportional to the inverse of one third of frequency beyond)
- DC zero adjustment:**
Automatic, in increments of 40 to 60 mA
- AC output noise:**
150 A calibre: ≤ 3 mV or 0.3 A peak-peak
1,400 A calibre: ≤ 1 mV or 1 A peak-peak
- Power supply:**
9 V alkaline (NEDA 1604A, IEC 6LR61)
5 V DC Micro USB type B
- Battery life:**
50 hours typical
- Consumption:**
Typical 10 mA (battery)
Typical 31 mA (5 V μUSB)
- "ON" LED indicator:**
"On" = In operation & battery level OK
"Flashing" = Battery life < 4 hours
"Colour = green" = APO ON
"Colour = yellow" = APO OFF
- "OL" LED indicator:**
Overload indication; current measured is too high for the calibre being used
- Effect of the power supply voltage:** Null
- Influence of temperature:**
≤ 3 % of the measurement + 100 mA DC/°C
- Influence of relative humidity:**
≤ 0.5% at 10% to 85% RH at ambient temperature
- Influence of an adjacent conductor carrying a 50 Hz AC current, situated 23 mm from the clamp:**
< 10 mA/A
- Influence of an external field 400 A/m @ 50 Hz:**
< 1.3 A
- Influence of conductor position Ø 20 mm in jaws:**
≤ 0.5 %
- Influence of frequency ⁽²⁾:**
 - Calibre 150 A: from 10 Hz .. 400 Hz: ≤ 1 % of Vs of 400 Hz .. 7 kHz: ≤ 3.5 % of Vs of 7 kHz .. 30 kHz: see curve
 - Calibre 1,400 A: from 10 Hz .. 400 Hz: ≤ 1 % of Vs of 400 Hz .. 10 kHz: ≤ 3.5 % of Vs of 10 kHz .. 30 kHz: see curve
- Common mode rejection:**
> 90 dB A/V @ 50 Hz
- Remanence:**
 - 0 to 100 A DC: 2.8 A typical
 - 0 to 200 A DC: 3.5 A typical
 - 0 to 400 A DC: 5 A typical
 - 0 to 800 A DC: 5.3 A typical
 - 0 to 1,200 A DC: 5.7 A typical
 - 0 to 1,400 A DC: 5.8 A typical



Mechanical specifications

- Max. jaw opening:**
39 mm
- Clamping capacity:**
Cables: Ø 39 mm
Ø 25.4 mm x 2
Busbars: 1 busbar 50 x 12.5 mm
2 busbars 50 x 5 mm or 31.5 x 10 mm
3 busbars 25 x 8 mm
4 busbars 25 x 5 mm
- Output:**
1.5 m double-insulated lead with safety male plugs (4 mm)
- Dimensions:**
236.5 x 97 x 44 mm
- Mass:**
520 g with battery
- Operating temperature:**
-10°C to +55°C
- Storage temperature:**
-40°C to +80°C

CURRENT CLAMP FOR AC/DC CURRENT

Model PAC26

- **Max. temperature of clamped conductor (measured):**
+90 °C (+110 °C at peak)
- **Max. jaw temperature:**
+80 °C
- **Relative humidity for operation:**
0 to 85 % RH with a linear decrease above 35 °C
- **Operating altitude:**
0 to 2,000 m
- **Casing protection rating:**
IP 40 (IEC 60529)
- **Drop test:**
1 m (IEC 60068-2-32)
- **Self-extinguishing capability:**
UL94 V1
- **Colours:**
Dark grey case with red jaws

Safety specifications

- **Electrical safety:**
Type A instrument, with double insulation or reinforced insulation between the primary, the secondary and the grippable part located under the guard as per CEI61010-1 & CEI 61010-2-032
- 600 V category III, pollution degree 2
- 300 V category IV, pollution degree 2
- **Electromagnetic compatibility (EMC):** :
Compliant with IEC 61326-1 (portable instrument)

Curves

150 A calibre

1,400 A calibre

Linearity for DC

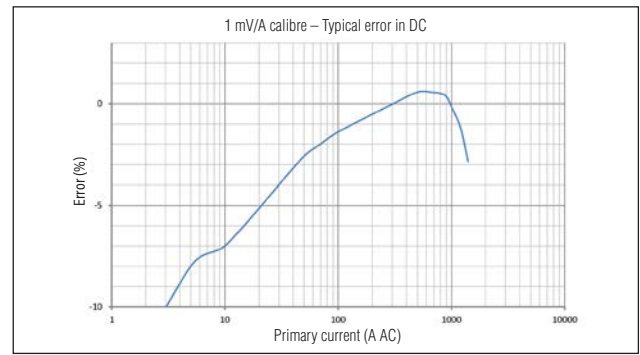
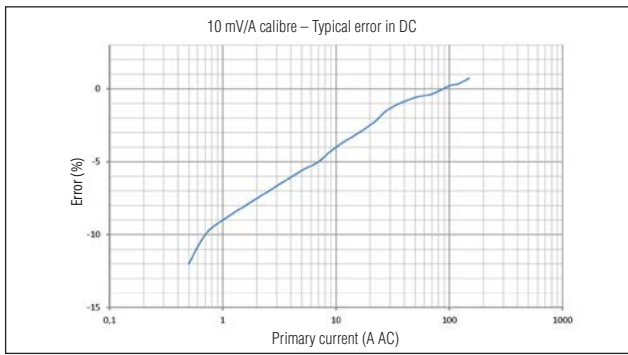

Linearity for AC

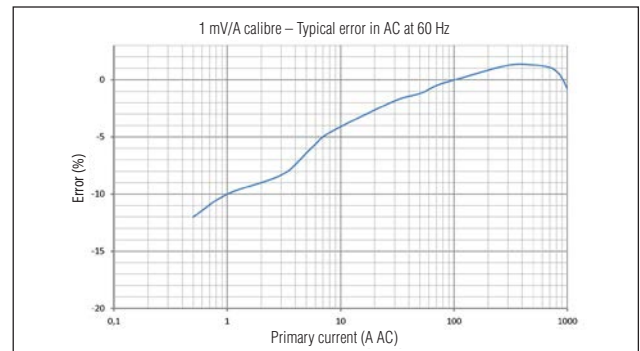
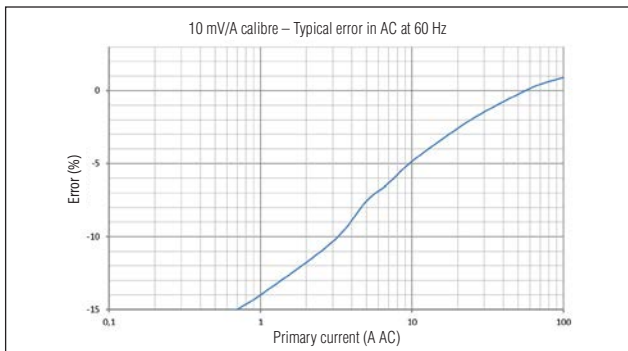

Phase shift

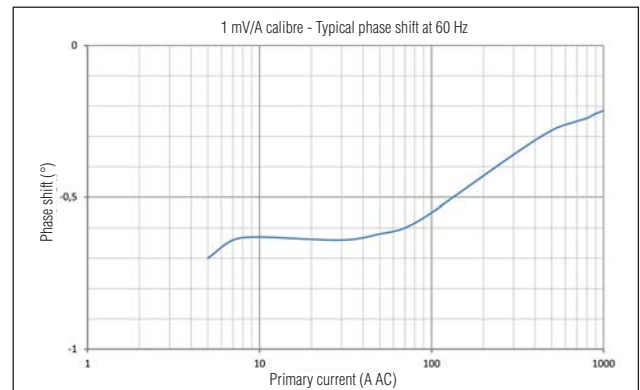

CURRENT CLAMPS FOR AC/DC CURRENT

Model PAC26

Curves

Limitation of the measurable current as a function of frequency

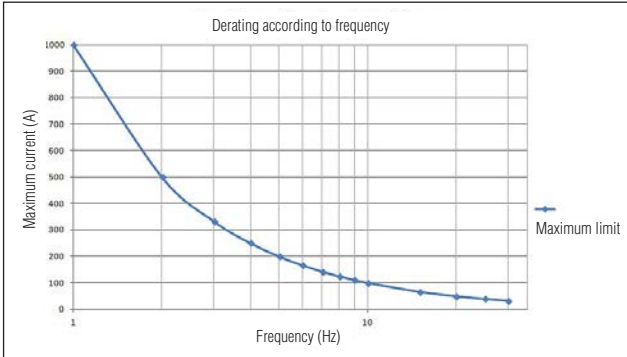

150 A calibre

1,400 A calibre

Frequency response

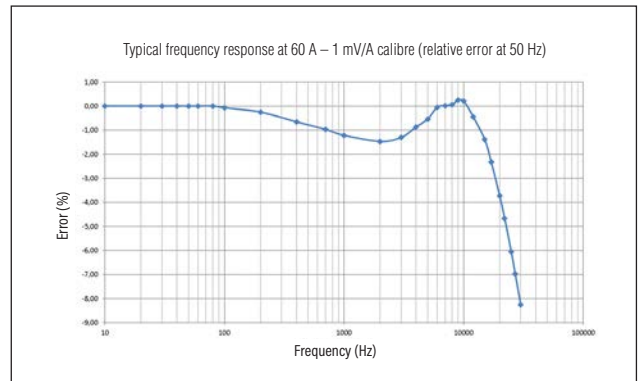
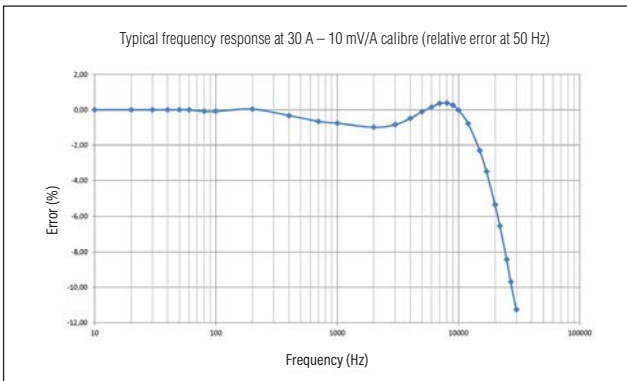

Frequency phase shift

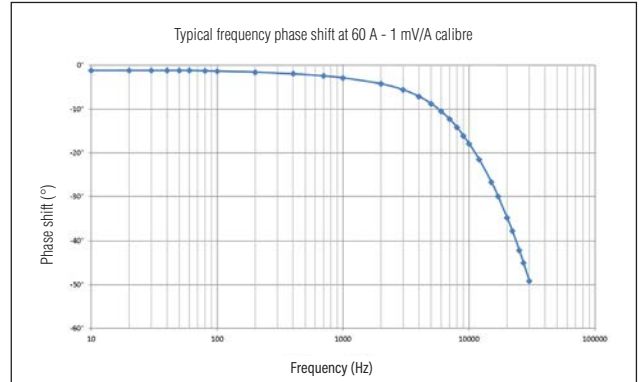
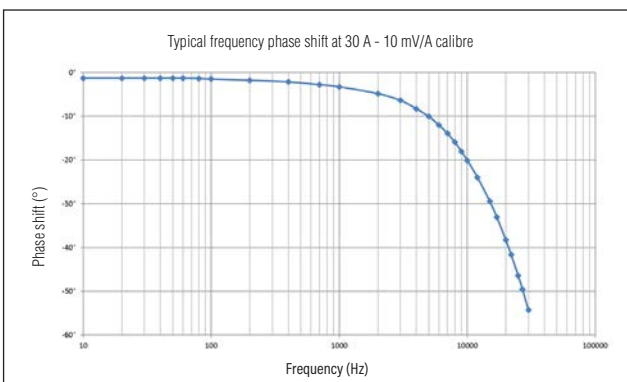

- (1) Conditions of reference:
 Temperature & humidity: 23 °C ± 5 °K, 20% to 75% RH
 Power supply: via a battery between 6 V and 9 V, via µUSB 5 ± 0.1 VDC
 Position of the conductor centred on the clamp markings
 Magnetic field: continuous Earth's magnetic field.
 No external alternating magnetic field.
 No electric field.
 Measurement for a sinusoidal DC current at 65 Hz.
 Instrument impedance: > 1 MΩ ≤ 100 pF.

- (2) Out of reference domain

To order	Reference
AC/DC current clamps, model PAC26, with battery and user manual	P01120126

CURRENT CLAMP FOR AC/DC CURRENT

Model PAC27 (insulated AC/DC current probe)

Current	100 A AC 150 A DC	1,000 A AC 1,400 A DC
Output	10 mV/A	1 mV/A

Description

The PAC27 model provides accurate measurement of AC or DC currents using the Hall effect principle. This mV-to-BNC output clamp (for direct reading on oscilloscopes, etc.) is equipped with an automatic DC zero system and a disengageable Auto Power Off (APO) function, and can be powered by a standard mains adapter via a Micro USB connector.

Electrical specifications

- Current range:**
0.2 A AC .. 100 A AC (150 A peak) / 0.4 ADC .. 150 A DC
0.5 A AC .. 1,000 A AC (1,400 A peak) / 0.5 ADC .. 1,400 A DC
- Output signal:**
1 mV AC+DC / A AC+DC (1.4 V for 1,400 A)
- Accuracy and phase shift ⁽¹⁾:**
- 150 A calibre

Primary current:	0.5 A .. 1 A	1 A .. 40 A	40 A .. 100 A	100 A .. 150 A (DC only)
Accuracy in % of output signal	≤ 3 % + 8 mV	≤ 3 % + 8 mV	≤ 1.5 %	≤ 1.5 %
Phase shift ⁽²⁾	Not specified	≤ 2°	≤ 2°	-

- 1,400 A calibre

Primary current:	0.5 A .. 3 A	3 A .. 100 A	100 A .. 200 A	200 A .. 800 A	800 A .. 1,000 A	1,000 A .. 1,400 A (DC only)
Accuracy in % of output signal	≤ 2 % + 1.5 mV	≤ 2 % + 1.5 mV	≤ 2.5 %	≤ 2.5 %	≤ 4 %	≤ 5 %
Phase shift ⁽³⁾	Not specified	≤ 2°	≤ 2°	≤ 1.5°	≤ 1.5°	-

- Bandwidth:**
DC .. 30 kHz at -3 dB (depending on current value)
- Rise time (10% to 90% of Vs)**
≤ 11 μs
- Fall time (90% to 10% of Vs)**
≤ 11 μs
- 10 % delay time:**
≤ 10 μs
- Insertion impedance:**
0.05 mΩ at 400 Hz, 3.4 mΩ at 10 kHz
- Maximum currents:**
3,000 A DC or 1,000 A AC continuous for a frequency < 1 kHz (limitation proportional to the inverse of one third of frequency beyond)
- DC zero adjustment:**
Calibre 150 A & 1,400 A:
Automatic, in increments of 40 to 60 mA
- AC output noise:**
 - 150 A calibre: ≤ 3 mV or 0.3 A peak-peak
 - 1,400 A calibre: ≤ 1 mV or 1 A peak-peak
- Power supply:**
9 V alkaline (NEDA 1604A, IEC 6LR61)
5 V DC Micro USB type B
- Battery life:**
50 hours typical
- Consumption:**
Typical 10 mA (battery)
Typical 31 mA (5 V μUSB)
- "ON" LED indicator:**
"On" = In operation & battery level OK
"Flashing" = Battery life < 4 hours
"Colour = green" = APO ON
"Colour = yellow" = APO OFF
- "OL" LED indicator:**
Overload indication; current measured is too high for the calibre being used
- Effect of the power supply voltage:**
Null
- Influence of temperature:**
≤ 3 % of the measurement + 100 mA DC/°C
- Influence of relative humidity:**
≤ 0.5% at 10% to 85% RH at ambient temperature
- Influence of an adjacent conductor carrying a 50 Hz AC current, situated 23 mm from the clamp:**
< 10 mA/A
- Influence of an external field 400 A/m @ 50 Hz:**
< 1.3 A
- Influence of conductor position Ø 20 mm in jaws:**
≤ 0.5 %
- Influence of frequency ⁽²⁾:**
 - Calibre 150 A: from 10 Hz .. 400 Hz: ≤ 1 % of Vs
of 400 Hz .. 7 kHz: ≤ 3.5 % of Vs
of 7 kHz .. 30 kHz: see curve
 - Calibre 1,400 A: from 10 Hz .. 400 Hz: ≤ 1 % of Vs
of 400 Hz .. 10 kHz: ≤ 3.5 % of Vs
of 10 kHz .. 30 kHz: see curve
- Common mode rejection:**
> 90 dB A/V @ 50 Hz
- Remanence:**
0 to 100 A DC: 2.8 A typical
0 to 200 A DC: 3.5 A typical
0 to 400 A DC: 5 A typical
0 to 800 A DC: 5.3 A typical
0 to 1,200 A DC: 5.7 A typical
0 to 1,400 A DC: 5.8 A typical



Mechanical specifications

- Max. jaw opening:**
39 mm
- Clamping capacity:**
Cables: Ø 39 mm
Ø 25.4 mm x 2
Busbars: 1 busbar 50 x 12.5 mm
2 busbars 50 x 5 mm or 31.5 x 10 mm
3 busbars 25 x 8 mm
4 busbars 25 x 5 mm
- Output:**
Coaxial cable 2 m long, terminated by an insulated BNC connector
- Dimensions:**
236.5 x 97 x 44 mm

CURRENT CLAMPS FOR AC/DC CURRENT

Model PAC27 (insulated AC/DC current probe)

- **Mass:**
520 g with battery
- **Operating temperature:**
-10°C to +55°C
- **Storage temperature:**
-40°C to +80°C
- **Max. temperature of clamped conductor (measured):**
+90 °C (+110 °C at peak)
- **Max. jaw temperature:**
+80 °C
- **Relative humidity for operation:**
0 to 85 % RH with a linear decrease above 35 °C
- **Operating altitude:**
0 to 2,000 m
- **Casing protection rating:**
IP 40 (IEC 60529)
- **Drop test:**
1 m (IEC 60068-2-32)
- **Self-extinguishing capability:**
UL94 V1
- **Colours:**
Dark grey case with red jaws

Safety specifications

- **Electrical safety:**
Type A instrument, with double insulation or reinforced insulation between the primary, the secondary and the grippable part located under the guard as per CEI 61010-1 & CEI 61010-2-032
 - 600 V category III, pollution degree 2
 - 300 V category IV, pollution degree 2
- **Electromagnetic compatibility (EMC):** :
Compliant with IEC 61326-1 (portable instrument)

Curves

150 A calibre

1,400 A calibre

Linearity for DC

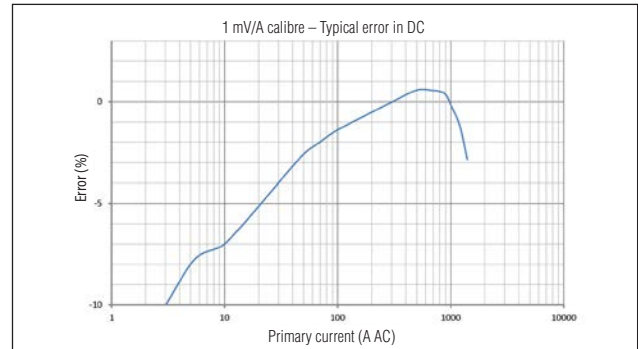
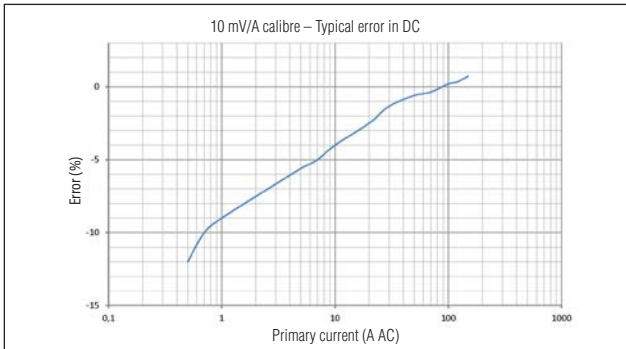

Linearity for AC

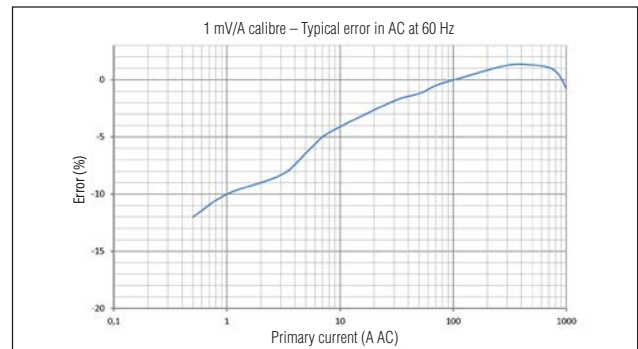
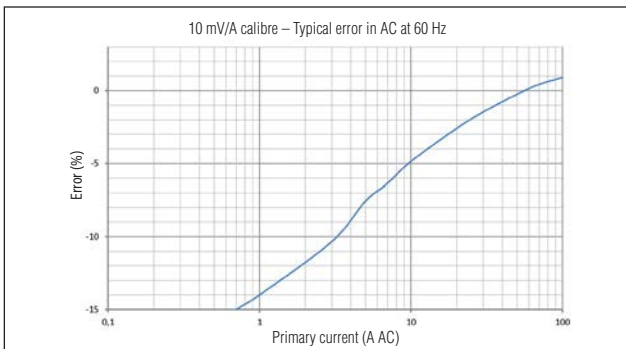

Phase shift

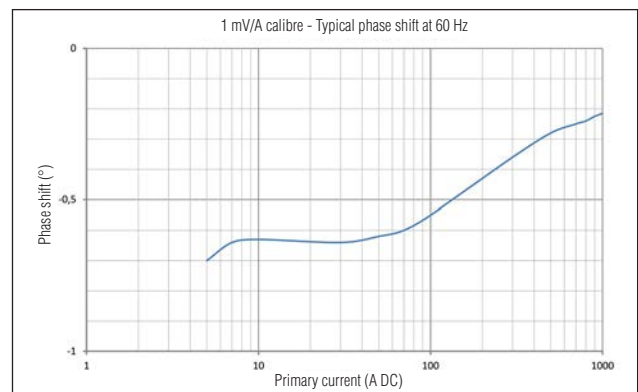
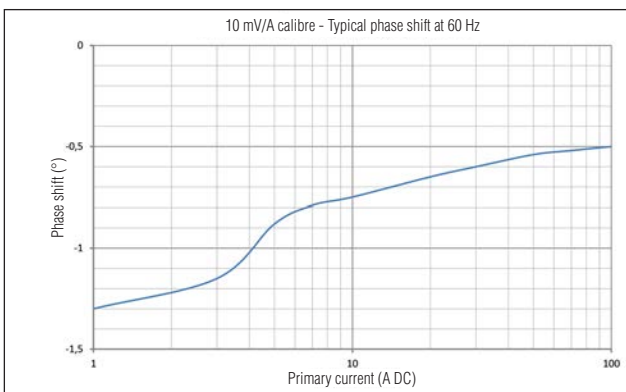

CURRENT CLAMP FOR AC/DC CURRENT

Model PAC27 (insulated AC/DC current probe)

Curves

Limitation of the measurable current as a function of frequency

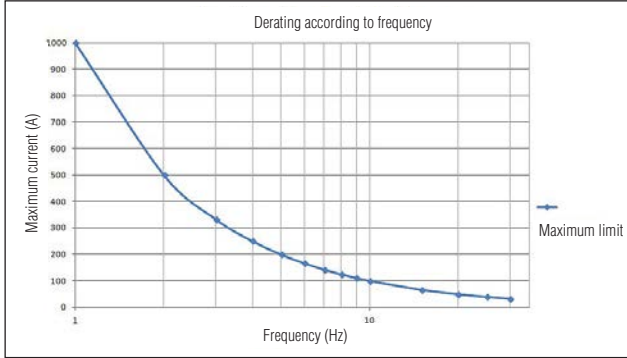

150 A calibre

1,400 A calibre

Frequency response

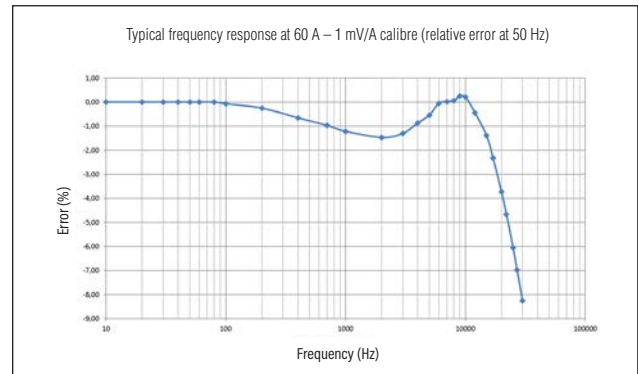
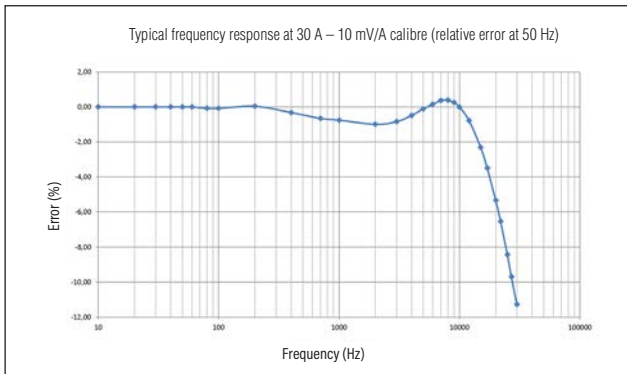

Frequency phase shift

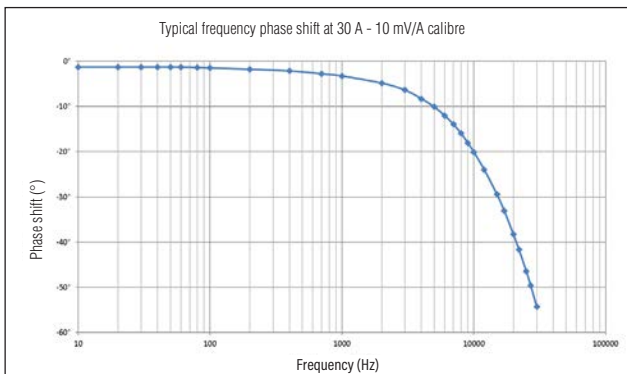

CURRENT CLAMPS FOR AC/DC CURRENT

Model PAC27 (insulated AC/DC current probe)

Curves

150 A calibre

1,400 A calibre

Pulse response

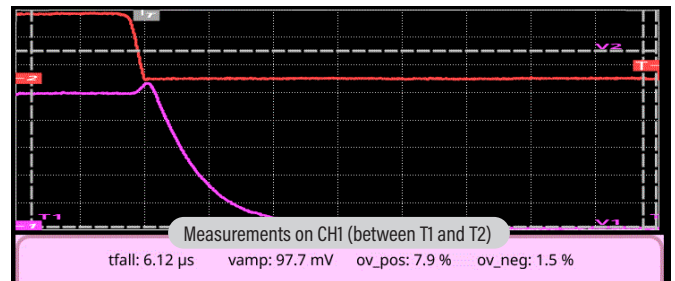
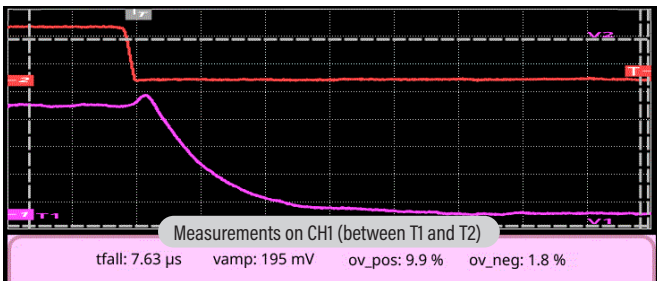
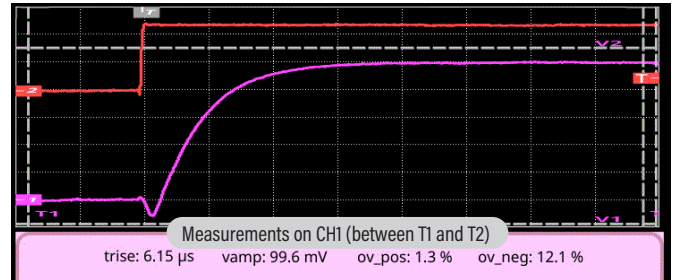
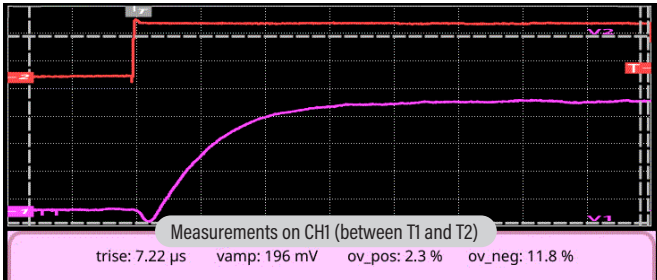

- (1) Conditions of reference:
- Temperature & humidity: 23 °C \pm 5 °K, 20% to 75% RH
 - Power supply: via a battery between 6 V and 9 V, via μ USB 5 \pm 0.1 VDC
 - Position of the conductor centred on the clamp markings
 - Magnetic field: continuous Earth's magnetic field.
 - No external alternating magnetic field.
 - No electric field.
 - Measurement for a sinusoidal DC current at 65 Hz.
 - Instrument impedance: > 1 M Ω \leq 100 pF.
- (2) Out of reference domain

To order	Reference
AC/DC current clamp, model PAC27 , for oscilloscopes, with battery and operating user manual	P01120127